



Letter Lok 4000

Versatile design and unsurpassed features will reduce your channel letter fastening costs.

- 25" throat
- Fast cycle times
- Clinch up to 10" deep letters
- Large table 30" x 60"
- UL recognized tooling*
- Simple tool adjustment
- Air powered

When you combine all the features, benefits and quality, the Letter Lok 4000 sets the standard for the channel letter industry.

*Norlok tooling components MP70001, MP70002 & MP70010. This is standard in all Letter Lok 4000 machines

INNOVATIONS IN ENGINEERING

Setting the standards

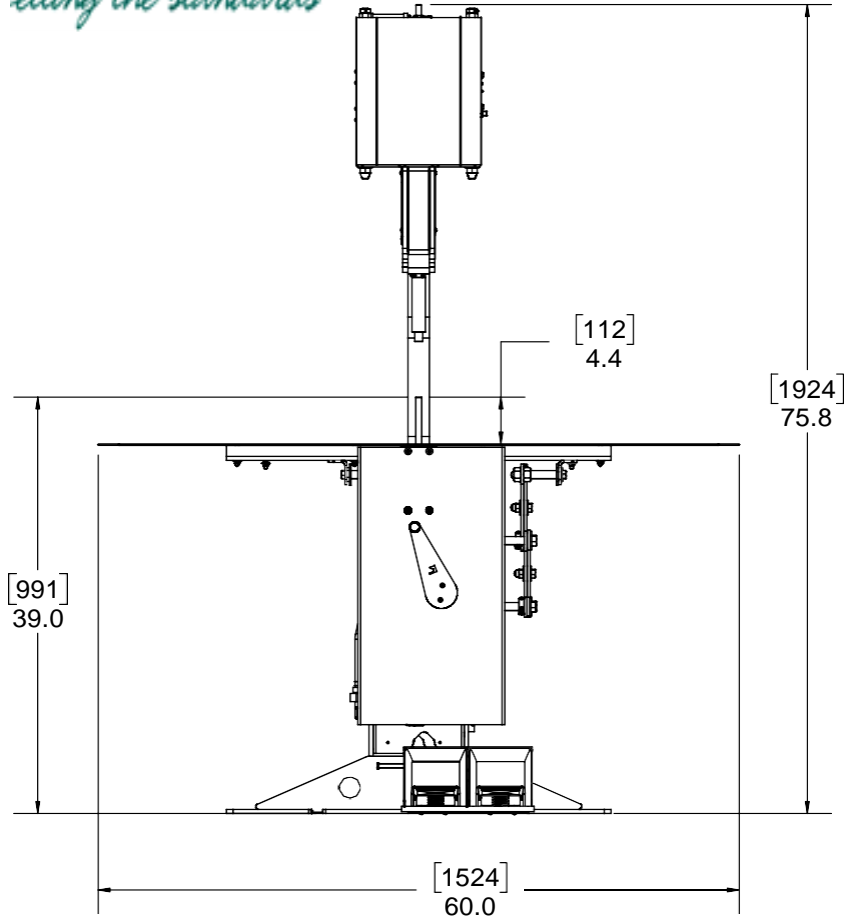

Lower stem rapidly moves out of the way with the press of the footpedal

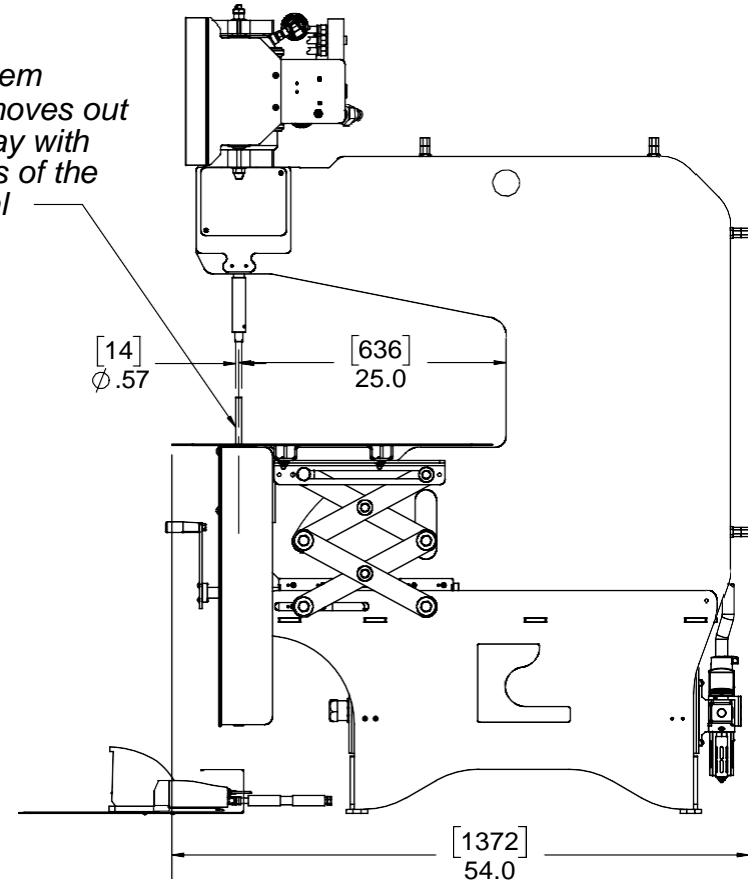

Material	Joined With	Net Max Thickness	Net Min Thickness
Aluminum	Clinch/SPR	0.160" / 4mm *	0.048" / 2.00mm
TPO	SPR	Contact Norlok	
Galvanized Steel	Clinch/SPR	0.120" / 3.8mm *	.030" / 0.50mm
Aluminum Composite	SPR	Contact Norlok	

* Self Piercing Rivets (SPR) are sold by Norlok. SPR can join thicker material and produce stronger bonds compared to clinch

- Stroke:** 1/4" [6mm] operating
8" [200mm] low pressure opening
- Throat:** 25" [635mm]
- Max Letter Height:** 8" [200mm] (10" [254mm] option available)
- Table:** 30" deep x 60" wide [760 x 1520 mm]
- Cycle Speed:** 80 CPM
- Air Requirements:** 70-100psi [5-6.8 bar]
Approx 0.8 cu ft free air per cycle